

INLINE FOAM INDUCTOR

TECHNICAL DATA :

MODEL	IG - Bronze material IA - Aluminium alloy with steel flanged end. IS - Stainless Steel
MAXIMUM SERVICE PRESSURE	12 BAR. (175 PSI)
FACTORY HYDROSTATIC TEST PRESSURE	25 BAR. (365 PSI)
MINIMUM WORKING PRESSURE	6.4 BAR. (93 PSI)
MAXIMUM BACK PRESSURE	65% of Inlet Pressure
NOMINAL SIZE	50, 65, 80, 100 & 150 MM
FINISH	Yellow paint
ORDERING INFORMATION	a) Inductor inlet Pressure. b) Foam solution flow required. c) Percentage of induction. d) Type of foam concentrate to be used. e) Maximum suction lift. f) Flange connection.

APPLICATION

Inline Foam Inductor is used to induct the foam liquid concentrate in water stream to supply proportioned solution of the liquid concentrate and water, to the foam producing equipment. The inductors are designed primarily for use in the fixed foam installation to provide a simple and reliable method of proportioning in constant flow applications. Each Inductor is designed for a predetermined water pressure to give the correct proportioning at that pressure and the discharge rate. The increase or decrease of the inlet pressure will result in an increase or decrease in the flow rate, which in turn will change the proportioning.

SPECIFICATION

Inductors are available in three different materials of construction, a wide range of flow from 75 to 3500 litres per minute at the inlet pressure between 6.4 to 12 bar as shown in the graph.

Each Inductor is accurately calibrated at the factory to match the flow, pressure and the induction requirement of the system. This enables to ensure and achieve the correct performance.



SYSTEM DESIGN DETAILS

The Inductor must be selected and installed in a hydraulically calculated system considering the limitation of permissible back pressure. The maximum back pressure allowed is expressed as 65% of pressure at the inlet of the inductor.

In the fixed foam system installation the inductor can be mounted above the concentrate storage tank. The maximum height of the Inductor suction pipe above the bottom of the storage tank to the inductor centre should not exceed 1.75 meters. A minimum of 600 mm of unobstructed straight pipe line should be provided at the inlet and outlet of the inductor. The inductor must be installed in a system having minimum of 6.4 bar inlet pressure at inlet of inductor.

The diameter of water supply pipe and water foam solution pipe should not be less than that of the diameter of the inductor. A shut-off valve provided in the induction line must be full bore on-off valve.

The non-return valve if fitted in the foam induction pipe line, then it must be supplied or recommended by Wilson, so that the induction rate is properly calibrated in factory before supply. For the best performance the inlet pressure at the inline inductor should be 6.8 bar or higher.

Installation and Maintenance



Inductor must be supported firmly to prevent strain on the inductor itself.

Qualified and trained person must commission the system. After few initial successful test an authorized person must be trained to perform inspection and testing of the system. It is recommended to carry out physical inspection of the system regularly. The system must be fully tested at least once in a year or in accordance with applicable NFPA codes or in accordance to the standard of the organization having local jurisdiction.

Do not turn off the system or any valve to make repair or test the system, without placing a roving Fire Patrol in the area covered by the system. The Patrol should continue until the system is back in service. Also inform the local security guard and control alarm station, so that a false alarm will not be signalled.

SELECTION of INLINE FOAM INDUCTOR SIZE

Size of inductor	Inductor K-Factor Range
50 NB	28.4 TO 85.00
65 NB	76.0 TO 170.00
80 NB	151.2 TO 340.20
100 NB	302.4 TO 680.30
150 NB	604.8 TO 1030.00

For selecting Inductor size, following formula to be used:

$$Q = K \cdot P \sqrt{\quad}$$

Q = Total solution flow rate in litres per minute.

K = Inductor constant

P = Inlet pressure in kg/sq.cm.

Example : To find K-Factor

Q = 200 LPM

P = 8.0 kg/sq.cm.

$$K = 200 \div \sqrt{8}$$

K = 70.71

This K=70.71 falls within the range of inductor with 50 NB size. Hence 50 NB inductor should be selected.

NOTES

- 1) It is recommended to select next higher size of inductor when the K-factor is very close to the higher range of model.
- 2) For the best performance the inlet pressure at the inductor should be 6.8 bar or higher.

- 3) A pressure gauge mounting socket at inlet and outlet of Inductor must be provided, which will help to analyze the system during commissioning. The socket can be plugged in once the system has been commissioned successfully.
- 4) The maximum permissible back pressure is 65% of inlet pressure. The system designer should consider and design the system with less than 65% back pressure.

INLINE FOAM INDUCTOR

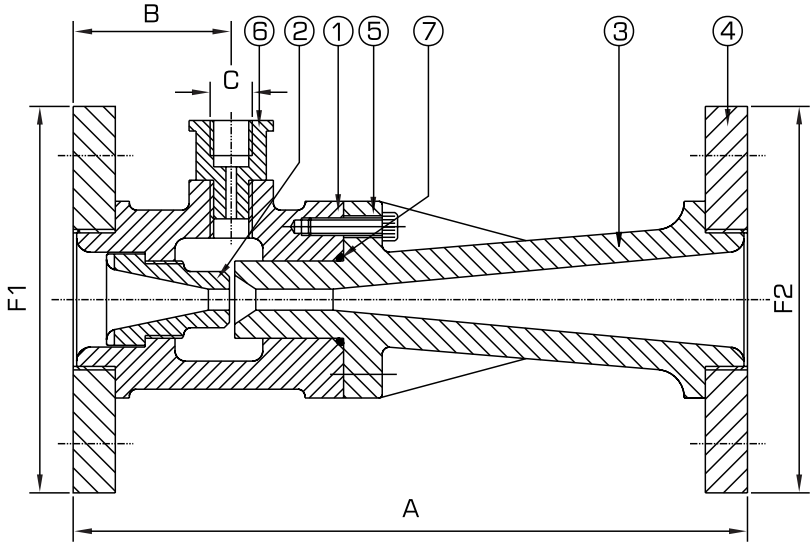

DIMENSION in millimeter (Approximate)

INDUCTOR SIZE	A	B	C	FLANGE SIZE F1/F2
50 NB	300	70	1" BSP	50 NB
65 NB	350	75	1" BSP	65 NB
80 NB	400	80	1" BSP	80 NB
100 NB	450	85	1¼" BSP	100 NB
150 NB	500	90	1¼" BSP	150 NB

MATERIAL OF CONSTRUCTION

Sr.No	Description	Material Model		
		A I	G I	S I
1	HOUSING	AL ALLOY	BRONZE	S.S. 304 ASTMA 351-CF8
2	NOZZLE	AL ALLOY	BRONZE	S.S. 304 ASTMA 351-CF8
3	DIFFUSER	AL ALLOY	BRONZE	S.S. 304 ASTMA 351-CF8
4	FLANGE	STEEL	BRONZE	S.S. 304 ASTMA 351-CF8
5	BOLT	S.S. 304	S.S. 304	S.S. 304
6	ORIFICE	BRONZE	BRONZE	S.S. 304
7	'O' RING	NEOPRENE RUBBER	NEOPRENE RUBBER	NEOPRENE RUBBER

- Dimension of Inlet/outlet flanges (F1/F2) are as per ANSI B16.5 150# & ANSI B16.24 for bronze material.

PRESSURE VS FLOW-PERFORMANCE CHARACTERISTICS

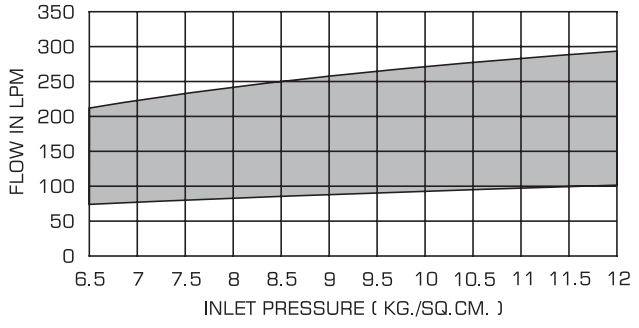

SIZE 50NB

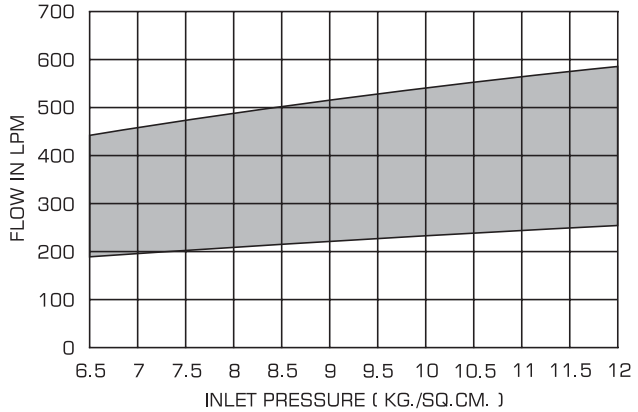

SIZE 65NB

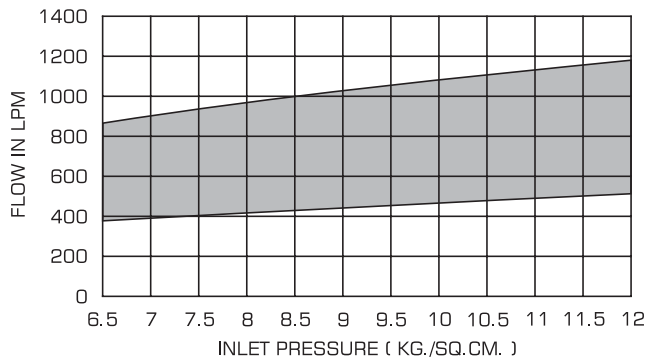

SIZE 80NB

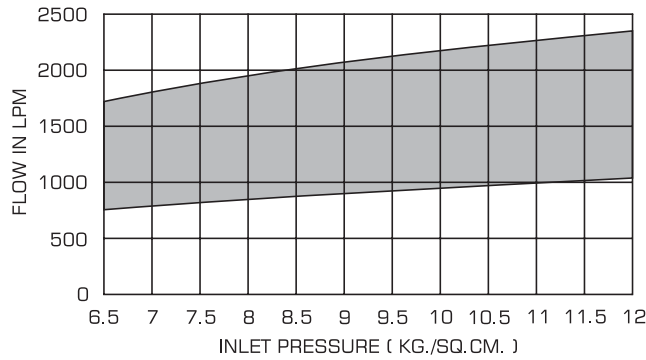

SIZE 100NB

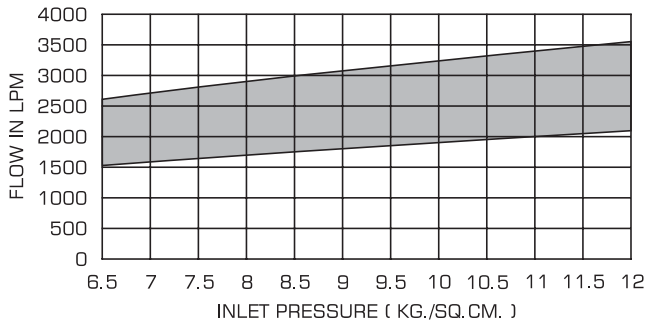

SIZE 150NB

TYPICAL MOUNTING ARRANGEMENT OF
INLINE FOAM INDUCTION SYSTEM



WITH INDUCTOR MOUNTING ON TOP OF THE TANK

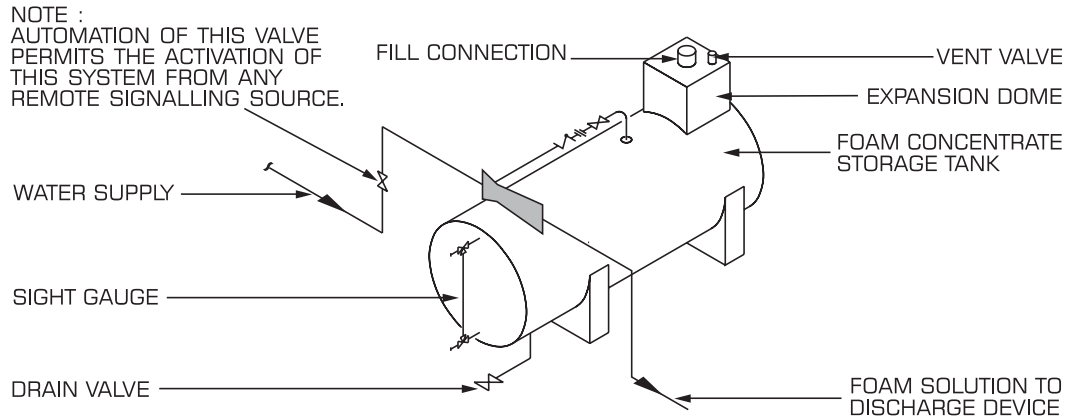

WITH INDUCTOR MOUNTING BELOW THE TANK

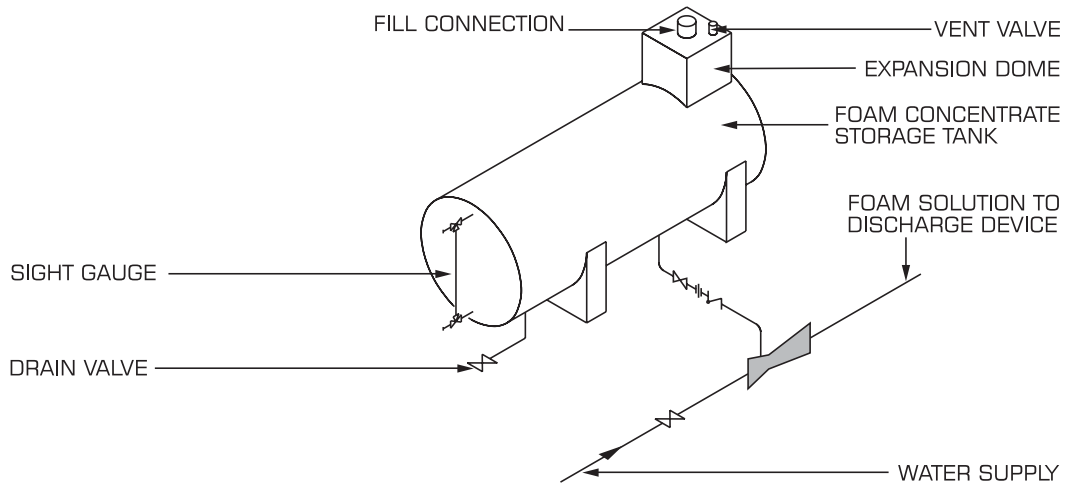

- INLINE INDUCTOR
- GATE VALVE OR BALL VALVE
- CHECK VALVE
- PIPE UNION

NOTE :
USE MINIMUM OF 600mm.
STRAIGHT UNOBSTRUCTED PIPE AT INLET
AND OUTLET OF EACH INLINE INDUCTOR.